



## 化纤长丝成套设备

CHEMICAL FILAMENT COMPLETE SET OF EQUIPMENT



## 恒天重工股份有限公司

HI-TECH HEAVY INDUSTRY CO.,LTD.

地址：河南省郑州市梧桐街258号  
邮编：450001  
电话：0371-85516208 85516209  
传真：0371-85516208 85516200  
网址：www.zzhyhx.com

ADD: NO.258, Wutong Street, Zhengzhou City,  
Henan, China  
P.C: 450001  
Tel: +86 371 85516208 85516209  
Fax: +86 371 85516208 85516200  
Web: www.zzhyhx.com



版本号：2021-01

## 恒天重工股份有限公司

HI-TECH HEAVY INDUSTRY CO.,LTD.

## 公司简介

恒天重工华萦公司，是恒天重工股份有限公司控股的子公司。华萦公司长丝成套设备研发制造具有十多年的经验，目前产品有POY、FDY系列纺丝机、高速卷绕头、热辊等产品，可以为客户提供POY、FDY的成套设备，适用于涤纶、锦纶、丙纶等化纤产品。

### 创新优势

华萦公司共享恒天重工股份有限公司的所有资源，华萦公司拥有高级专业研究开发人员多人，同时与国内外多家知名大学及科研院所、知名专家开展广泛的合作，不断推出新的适应不同品种的长丝生产方案。公司一直致力于化纤长丝装备的发展，不断开发出适应市场需求的新产品，在市场上保持技术领先。

### 加工实力

恒天重工股份有限公司作为华萦公司的加工基地拥有多种多样的、具备世界一流水平的机加工及检测设备。加工设备精良、体系齐全，各类设备达2700余台。华萦公司本身也拥有多台进口的精密专用设备以及化纤长丝装配生产线。

### 品质保障

恒天重工华萦公司已具有现代企业制度，以及先进、严格的管理机制和质量控制体系，公司以科技创新为动力，不断增强自己的核心竞争力。

恒天重工华萦公司竭诚欢迎您惠顾洽谈。

## Brief Introduction

As a subsidiary of HI-TECH HEAVY INDUSTRY CO., LTD ( HTHI ), HI-TECH HEAVY INDUSTRY HUAYING COMPANY has more than ten year' s experience in developing and manufacturing. HUAYING COMPANY has developed POY, FDY series spinning machine, high speed winder, hot roller and etc. Now It can supply complete set of POY, FDY equipment for PET, Nylon or PP and other chemical fiber product.

### Innovation advantages

Hi-tech Heavy Industry Co.,Ltd. is the technology support of Huaying Company, which has many senior professional research personnel and cooperates with famous universities and research institutes. Huaying Company continuously puts new kinds of filament production solution into the market.

### Processing strength

As a processing base of Huaying, HTHI has 2700 sets of various types of equipment which including world-class processing and testing equipment, sophisticated equipment and complete system. Huaying also has many core imported precision special equipment and assembly line for filament equipment.

### Quantity Guarantee

Huaying Company has a modern enterprise system, as well as advanced & strict management mechanism and quality control system. It takes the scientific and technological innovation as the motivity to enhance their core competitiveness. Huaying Company We sincerely welcome you to negotiate with us.

## 荣誉资质 Honors

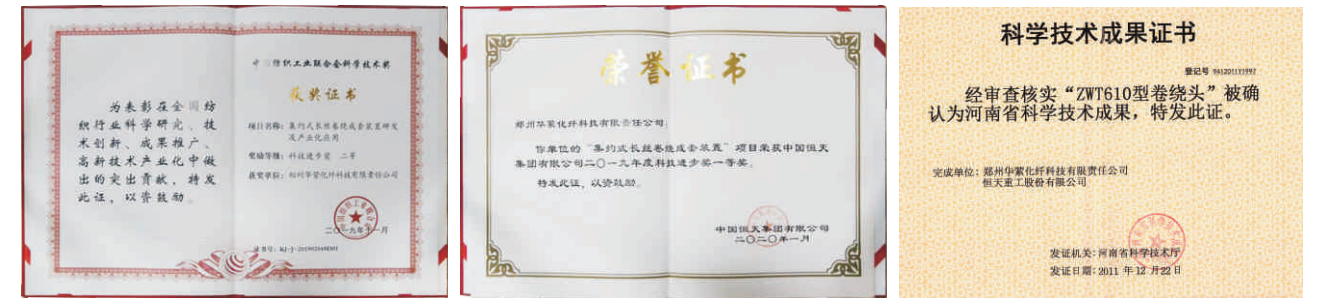

质量管理体系认证证书

质量管理体系认证证书

## 先进的装备 Advanced equipment



三坐标测量仪  
Three coordinates measuring machine



电子万能试验机  
Universal Material Testing Machine



卧式加工中心  
Horizontal Processing center



测高仪  
Altimeter



高速平衡机  
High speed balancing machine



高精度内圆磨床  
High precision internal grinder

## 长丝成套设备

为用户提供品种规划、全套工程设计；厂房建设条件，高可靠性的全套长丝生产设备，可提供整体技术、一站式解决。

### 工程范围：

- ◎ 涤纶、锦纶、丙纶长丝成套工程及设备；
- ◎ 复合丝长丝成套工程及设备；
- ◎ 工业丝长丝成套工程及设备；
- ◎ 各种差别化纤维长丝成套工程及设备。

### 技术服务范围：

- ◎ 工艺服务及指导
- ◎ 提供土建条件
- ◎ 公用工程设计及辅助配套
- ◎ 纺丝工序及卷绕工序设备
- ◎ 电气控制系统

## Chemical Filament Complete Set Of Equipment

Supply the service of product plan,complete engineering design,plant construction condition,high reliable complete set equipment,complete technology and one stop solution.

### Scope of project:

- ◎ PET,PA and PP filament complete engineering and equipment.
- ◎ Bi-component filament complete engineering and equipment.
- ◎ Industrial varn complete engineering and equipment.
- ◎ Various differential filament complete engineering and equipment.

### Scope of technical service:

- ◎ Process service and guidance
- ◎ Supply civil construction condition
- ◎ Utility and auxiliary equipment design
- ◎ Spinning and Take up equipment
- ◎ Electrical control system

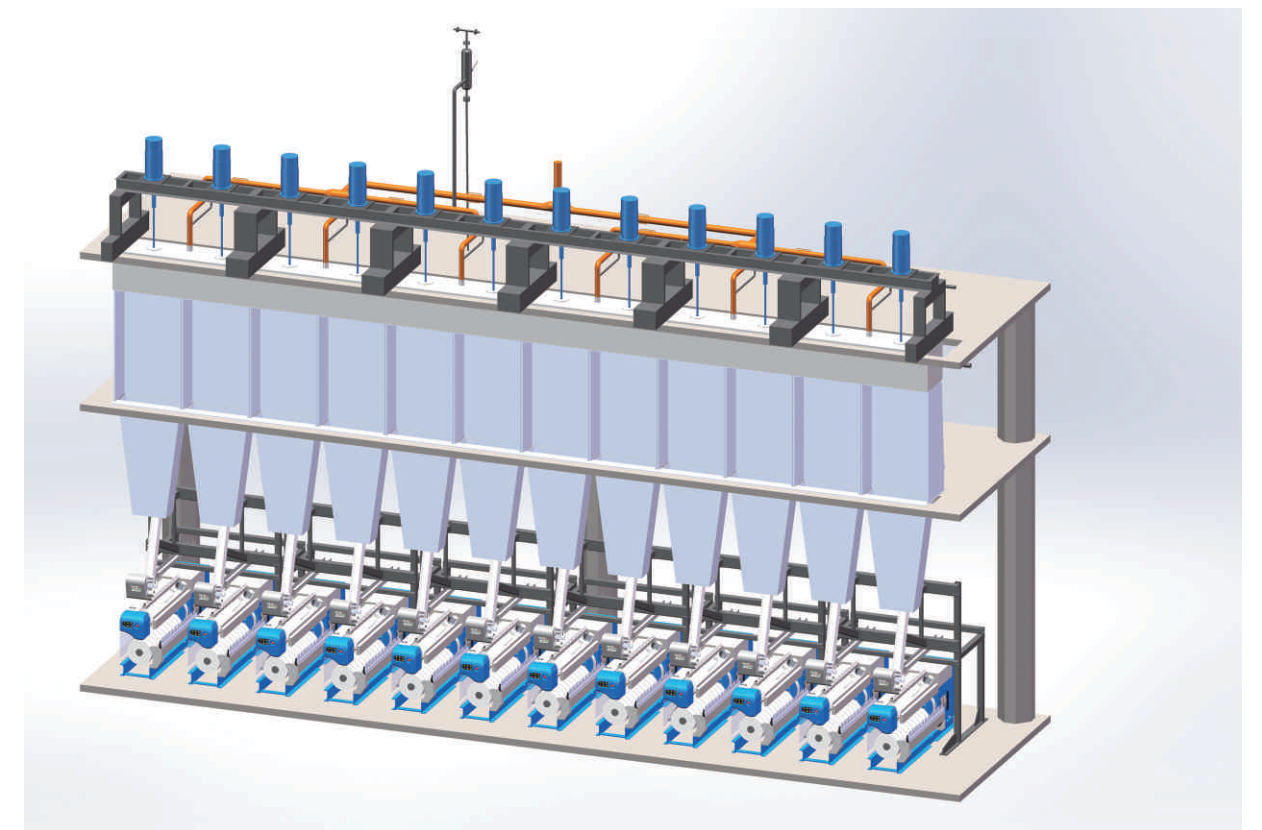

## POY纺丝应用方案

恒天重工华索公司致力于为用户提供高效、优质和节能的POY纺丝应用方案。随着技术的发展，产能最大化及效率的提升成为项目实施的主旨，产品的质量稳定、设备的运转可靠及高效节能是提高项目收益的保障。

### 产品涵盖范围广，设备系列化，机型齐备。

产品涵盖范围广，适用纤度范围在100~500D，最高可到288孔。纺丝箱体及组件设备系列化，纺丝组件系列化设计，喷丝板直径从 $\Phi 50 \sim \Phi 120$ 。最小位距可到800，有利于充分利用空间，提供产能和投资收益率。

### 实现高成品率及操作更便捷。

### 优化设计，精细制造是保证产品质量的基础。

可为用户提供智能化管家系统，方便管理层掌握设备运营情况，实现集中控制，同时可为用户提供远程在线监控及诊断功能，让生产管理更科学，提高效率。

## POY solution

Huaying Company devotes to supply high efficiency,superior and energy saving POY solution to customer.Along with the development of technology,capacity maximization and efficiency

improving becomes purport of project implement.Stable quality of products,reliable running of equipment and energy saving are guarantee of project profit improvement.

### Product covers wide range,serilization equipment and complete model.

Product range is wide,suitable denier range is 100-500D,maximum no.of filament can reach 288F.Spin beam and spinning pack are in series,spinning pack design is in series,diameter of spinneret is from  $\Phi 50 - \Phi 120$ mm.Minimum pitch can be 800mm,which is good for space best usage and increase the capacity and rate of return on investment.

### Realize high finished product ratio and easier operation.

### Optimal design and elaborate manufacturing is the foundation to guarantee product quality.

We can supply intelligent management system to help management to know machine running condition better and realize centralized control.And also can supply remote on line monitor and diagnostics fuction to make production management more scientific and improve the efficiency.

## FDY纺丝应用方案

恒天重工华索公司可为用户提供PET、PA6/PA66、PPI以及其他原料生产高品质的FDY纺丝应用方案。降低从纺丝到卷绕断头及故障率是提高生产效率的保证。

### A.多孔丝及超细旦丝等品种的解决方案

针对单丝纤度 $\leq 1$ dpf,孔数为144的超细旦及多孔丝，采用自外向内的冷却吹风方式，设备适用品种范围广，可以满足用户的不同要求。FDY项目实施过程中，从纺丝到卷绕，纤维经过之处（从管道及导丝瓷件等），均为精心挑选，以确保生产质量优异的长丝产品。

### B.高速高效的FDY项目施工方案

丰富的经验可为项目提供优良的施工方案，合理配置设备，实现最低吨消耗。高速高效的FDY项目施工方案，在保证高速高效及低消耗的前提下，强调操作简单，低废丝率及节能。

### C.热辊的优势

在高速、高温工况下运转平稳可靠，适用品种范围广。

## FDY solution

Huaying Company can supply high quality FDY solution by PET,PA6/PA66,PP and other material.Reducing yarn breakage and faulty from Spinning to Take up is the guarantee of efficiency improvement.

### A.Multi filament and fine denier filament solution.

Against single filament denier is less than 1 dpf or no.of filament is 144F fine denier and multi filament,we use the quenching type of out-to-in,this is suitable for widely product range and can satisfy different requirement from customer.During FDY procedure,from spinning to take up,all pipes and ceramic parts which contact the yarn are carefully selected to make sure good quality yarn.

### B.High speed and efficiency FDY project construction scheme.

Rich experience can supply exellent construction scheme and proper configuration to achieve lowest consumption. High speed and efficiency FDY project construction scheme stresses easy operation,low waste yarn percentage and energy saving based on the condition of high speed and high efficiency.

### C.Advantage of hot godet.

Running stable and reliable on high speed and high temperature condition, suitable for widely product range.



## 工业丝/母丝/单板单丝 纺丝应用方案

品种适用范围：PET/PA6/PA66

纤度范围：1000~3000D，工业丝（PET）最大断裂强度≥9 g/d

2位/纺丝箱,工业丝丝饼数2/4/6头/位，母丝4/6/8头/位，单板单丝16/20/24头/位；

特殊设计的电加热缓冷结构，可有效保障丝束品质；

灵活、紧凑的热辊组合方案，多级牵伸，精准温控，热辊温度范围200~250℃；

采用ZWT等系列全自动高速卷绕机，满足工业丝较大张力卷绕需求，保证丝饼成型良好。

## Spinning Applications of Industrial Yarn/Main Yarn or Single-Board Mono-filament

Scope of Application: PET/PA6/PA66

Range of Denier: 1000~ 3000D, Max. Fracture Strength of Industrial Yarn (PET) ≥9 g/d

2 pos spinning beam, number of industrial yarn bobbin 2/4/6 ends/pos, mother yarn 4/6/8 ends/pos, Single-Board Mono-filament 16/20/24 ends/pos;

It is used a special design with electric heating and slow cooling structure, in order to effectively ensure the quality of the tow;

It is adopted the solution of flexible and compact hot roll combination, multi-stage draft, precise temperature control, temperature range of hot roll 200~250℃;

It is equipped with type ZWT series automatic high-speed winding machine to meet the winding needs of industrial yarn with large tension and ensure a good shape of bobbin.

## 复合丝纺丝应用方案

PA6/HDPE/ COPET / PET复合丝生产线适用于皮芯型、裂片型、并列型、海岛型等双组份复合长丝；

双箱/三箱纺丝箱结构，配合相互独立热媒系统，满足不同组份熔体的输送，精准温控；

下装式复合纺丝组件，紧凑、可靠、节能；

可选择采用两段可调式侧吹风装置，风速均匀稳定，满足多种品种工艺要求及丝束成型；

采用ZWT/ZWB系列全自动高速卷绕头，切换成功率高，丝饼成型良好。

## Spinning Application of Composite Filament

PA6/HDPE/ COPET/PET composite filament production line is suitable for Sheath-core, Laminated, side by side, sea island and other two-component composite filament;

Double pos spinning beam/three pos spinning beam which is equipped with independent thermal medium system to meet the delivery of different components of melt and accurate temperature control;

Lower-installed composite spinning assembly, it is compact, reliable and energy saving;

It can choose to adopt two-stage adjustable side-blowing device, and the speed is uniform and stable, in order to meet the process requirements of varieties and tow forming;

It is adopted type ZWT/ZWB series automatic high speed winder with high success rate of switching and good shape of bobbin.

## 纺丝箱体

### 主要特点

- ◎箱体内部温度场均匀一致；
- ◎箱体保温采用复合保温形式，节能环保；
- ◎组件采用下装形式，避免烟囱效应。

## Spinning beam

### Main feature

- ◎ Spinning beam internal temperature fields are uniform.
- ◎ Spinning beam insulation is compund insulation type, it is energy saving and environmental.
- ◎ Spinning pack is bottom mounted to prevent from stack effect.

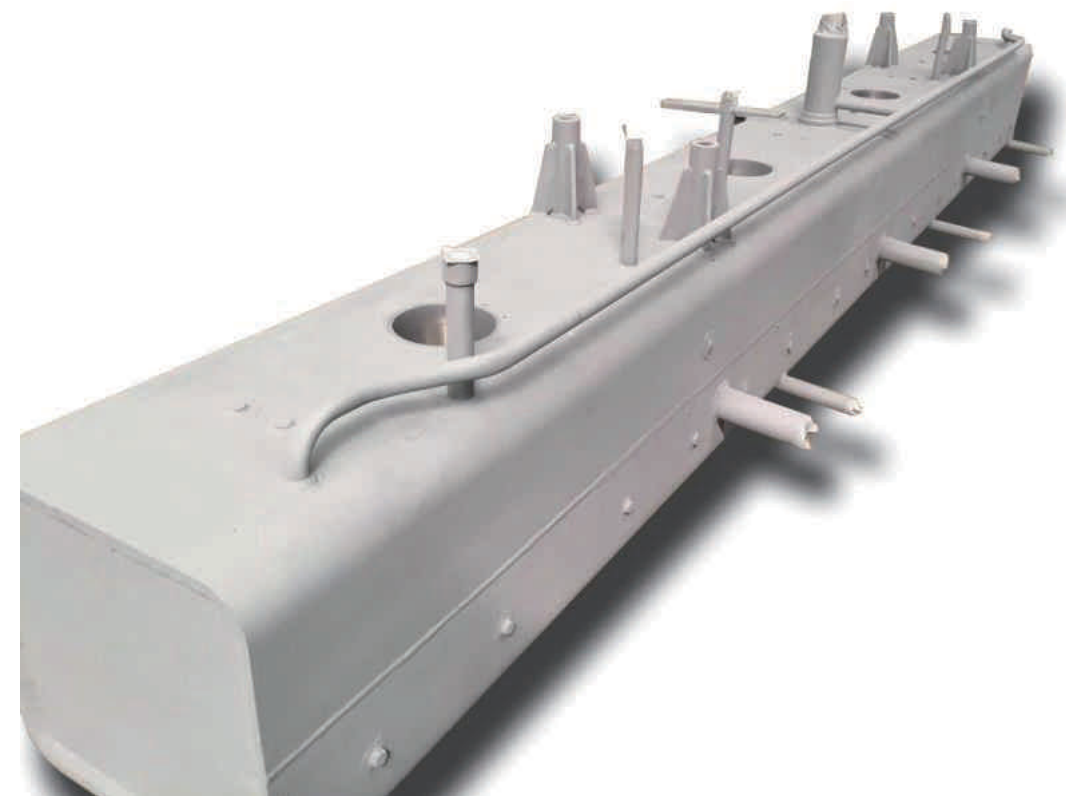

### 主要技术规格 Main Specification:

项目 Item	纺丝箱体 Spinning beam		
设备型号 Model No.	ZK2401系列	Zk2402系列	Zk2403系列
试用组件形式 Spinning pack type	单腔组件 Single channel	双腔DIO组件 DIO	双组份复合纺 Bi-component
适纺品种 Product	POY,FDY 80~500(d)/24~144(f)	POY,FDY 50~200(d)/72~288(f)	COPET/PET/PBT/PA6/PE/PP的并列/皮芯/海岛/桔瓣等多种形式的复合 Side by side, sheath&core, sea-island, segmented, etc.
位距 Pitch	900~1600	800~1300	
每位头数 End/pos	6,8,10,12,14,16	8,10,12,	

## 冷却及上油装置

### 主要特点

- ◎侧吹上油装置机械稳定性强、易操作、适用常规聚合物。
- ◎环吹风上油装置适用于多孔细旦丝，能够确保细旦丝的充分冷却，同时降低冷却工艺风的消耗，同比节能60%~80%。
- ◎吹风顶部无风带长度可根据工艺要求进行调整。
- ◎吹风与纺丝箱体间定位准确，密封可靠。
- ◎冷却风速场的相对均匀。



## Quenching and oil finish system.

### Main feature

- ◎ Cross quenching oil finish system has good mechanical stability and easy operation, it is suitable for normal polymer.
- ◎ Radial quenching oil finish system is suitable for multi filament and fine denier filament, it can make sure sufficient cooling and reduce the cooling air consumption, which can save energy by 60%~80%.
- ◎ The length of calm zone above quenching can be adjusted as per process requirement.
- ◎ Quenching and spinning beam positioning is accurate and sealing is reliable.
- ◎ Quenching air speed is uniform.

### 主要技术规格 Main Specification:

项目 Item	侧吹风上油装置 Cross quenching oil finish system	环吹风上油装置 Rarial quenching oil finish system
设备型号 Model No.	ZK2501系列	Zk2502系列
吹风方式 Quenching type	侧向吹风 cross quenching	由外向内环向吹风 Radial quenching out-to-in
适纺品种 Product	80~500 ( d ) / 24~144 ( f )	50~200 ( d ) / 48~288 ( f )
	dpf: 1.0~6.0	dpf: 0.5~1.0
位距 Pitch	800~1600	900~1300
每位头数 End/pos	8, 10, 12, 14, 16	8, 10, 12

## ZLK207A卷绕机

适用于涤纶和锦纶的POY，结构稳定、紧凑，空间占用少，减少了用户操作成本并提升生产效率；能够根据用户需求个性化定制配置组合。

## ZLK207A Take Up Machine

It is suitable for PET and PA POY, with stable and compact structure and less space, it can reduce the running cost and improve production efficiency. Customization is available based on customer's specific needs.

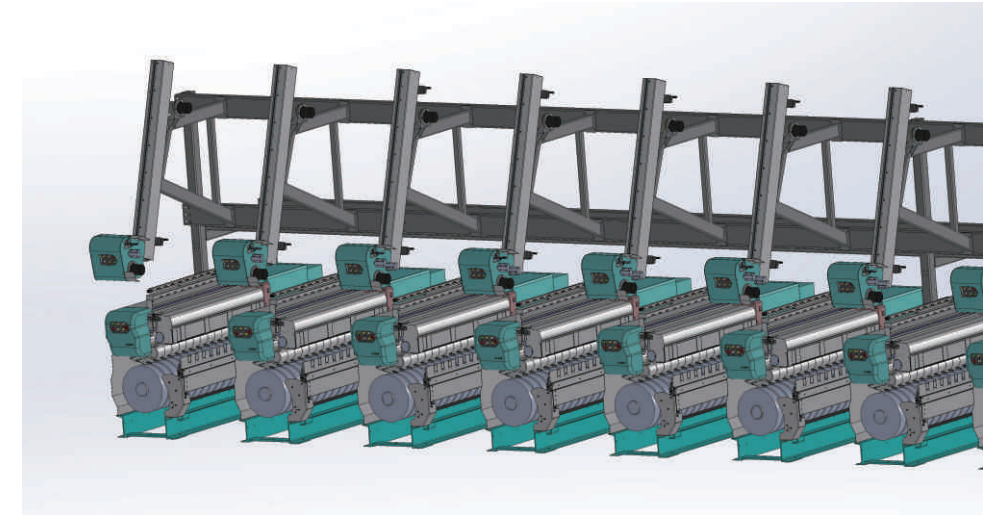

### 主要技术规格 Main Specification:

卷绕机型号 Winder Model	导盘型号 Godet Model	电机规格 Motor spec	辊面尺寸mm Godet surface size	适纺头数 End/pos	最小位距mm Min pitch	最高速度m/min Max speed
ZLK207A	TK2030	4极同步电机 4 poles synchronous motor	Φ100x100	6、8、10、12	800	3500
	TK2030-140		Φ100x140	14、16、18		



## ZWT 系列凸轮滑梭式卷绕头 ZWT Cam type Winder

ZWT 系列卷绕头是华索公司最具代表性的高速卷绕头。具有高可靠性、高生产率、高退绕率等特点，采用凸轮滑梭式横动装置，能满足长锭轴、大卷装的需求。

### 主要特点:

- ◎背负式控制柜：抗干扰能力强，有效节省用户的现场施工及电缆采购成本。
- ◎连续接触压力控制：根据不同的纺丝品种，通过上位机设定合适的压力曲线。
- ◎多段精密卷绕：丝饼成型良好，丝饼过尾率高。
- ◎主动压辊：有效的保护底层丝质量，并拓展了纺丝品种适用性。
- ◎切换：采用伺服系统控制卷绕切换，卷绕切换平稳、可靠。

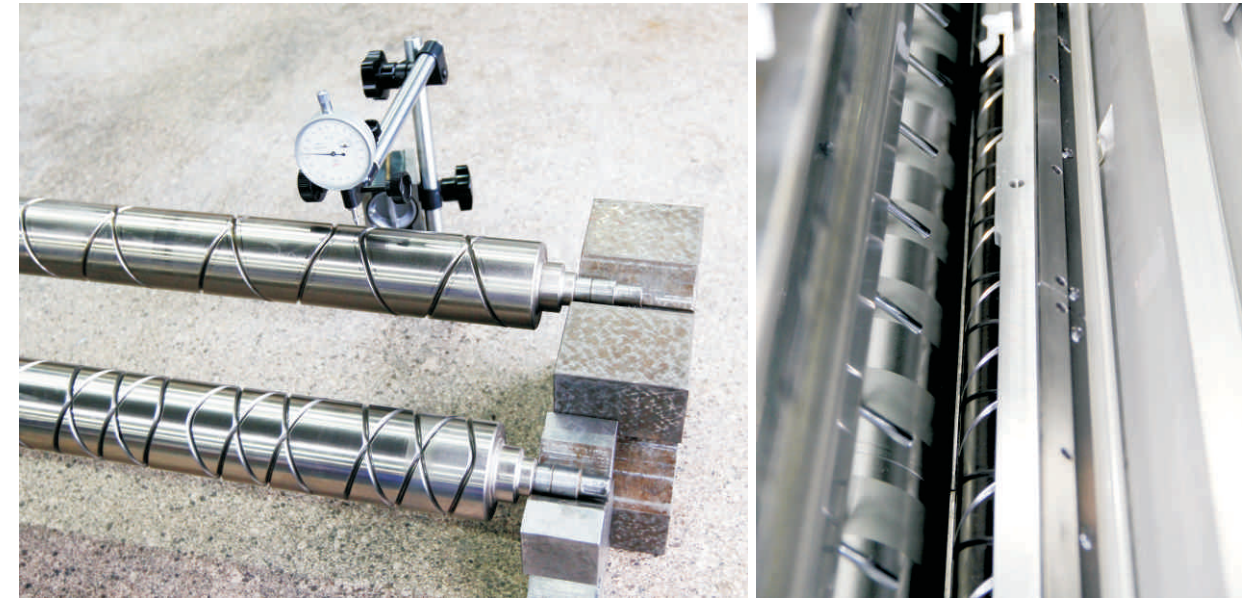

ZWT Winder is the most typical Winder from Huaying company. It has the advantages of high reliable, high production rate and high unwinding rate, ect. It is Cam traverse type which can satisfy the requirement of long chuck and big volume bobbin.

### Main feature

- ◎Backpack control panel: with good interfering capability, it can reduce the construction and cable cost.
- ◎Continious contact pressure control: set proper pressre curve through DCS system based on different product.
- ◎Step precision winding: it can have good bobbin shape and higher tail yarn transfer rate.
- ◎Drive type contact roller: protect bottom layer yarn quality and increased suitability of product.
- ◎Change over: with servo system to control winding change over and make the change over to be stable and reliable.

### 主要技术规格 Main Specification:

锭轴长度 Chuck length	卷绕速度 Winding speed	纸管规格 Tube dimension	卷装直径 Package	卷装容积 (dm <sup>3</sup> )/动程 (mm) Volume(dm <sup>3</sup> )/stroke length (mm)									
				4	6	8	10	12	14	16	18	20	
mm	m/min	Φ	Φ										
1200	2500-5500	110*125	435	36.13/265	23.17/170	16.36/120	-	-	-	8.18/60	-	-	
1380	2500-5500	110*125	435	-	28.63/210	20.45/150	-	12.27/90	-	8.12/61	-	-	
1380	2500-5500	125*140	435	-	-	-	-	11.99/90	-	-	-	-	
1500	2500-4500	110*125	435	-	29.31/215	22.16/162.5	17.04/125	13.77/101 12.95/95	11.32/83	9.95/73	8.18/60	-	
1500	2500-5500	125*140	435	-	-	21.65/162.5	16.65/125	13.46/101	-	9.72/73	-	7.19/54	
1680	2500-4800	125*140	435	-	-	23.98/180	-	15.99/120	-	11.05/83	-	8.52/64	
1800	2500-4800	125*140	435	-	-	-	-	16.65/125	-	11.72/88	9.99/75	9.32/70	
1860	2500-4000	125*140	435	-	-	-	-	17.31/130	-	-	-	-	

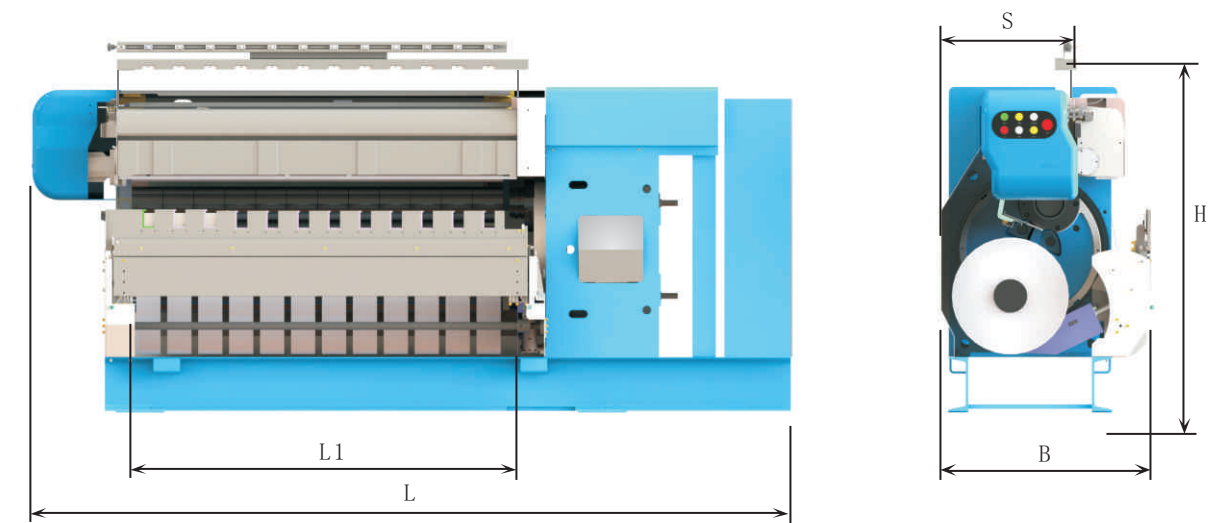

### 外形尺寸参数 Dimensions

L1	L	B	H	S
mm	mm	mm	mm	mm
1200	2640	784	1260-1650	514
1380	2820	784	1260-1515	514
1500	2940	784	1260-1515	514
1680	3225	784	1260-1385	514
1800	3390	784	1260-1385	514
1860	3450	784	1260-1385	514

## ZWB 系列双转旋翼式卷绕头 ZWB Birotor Winder

ZWB系列卷绕头是华萦公司开发的双转旋翼式卷绕头，具有可靠性高、生产率高等特点，能满足长锭轴、高速、多丝饼的需求。

### 主要特点:

- ◎背负式控制柜：抗干扰能力强，有效节省用户的现场施工及电缆采购成本。
- ◎连续接触压力控制：根据不同的纺丝品种，通过上位机设定合适的压力曲线。
- ◎多段精密卷绕：丝饼成型良好，丝饼过尾率高。
- ◎主动压辊：有效的保护底层丝质量，并拓展了纺丝品种适用性。
- ◎切换：采用伺服系统控制卷绕切换，卷绕切换平稳、可靠。
- ◎全机瓷件：采用进口品牌，成形板为整体陶瓷材质。



ZWB Winder is Birotor Winder developed by Huaying company, it has the advantages of good reliable and high production rate etc, it can satisfy the requirement of long chuck, high speed and multi end.

### Main feature:

- ◎ Backpack control panel: with good anti-jamming capability, it can reduce the construction and cable cost.
- ◎ Continuous contact pressure control: set proper pressure curve through DCS system based on different product.
- ◎ Step precision winding: it can have good bobbin shape and higher tail yarn transfer rate.
- ◎ Drive type contact roller: protect bottom layer yarn quality and increased suitability of product.
- ◎ Change over: with servo system to control winding change over, and make the change over to be stable and reliable.
- ◎ Ceramic parts: all the ceramic parts are Germany/Japan brand, shaping plate is fully ceramic material.

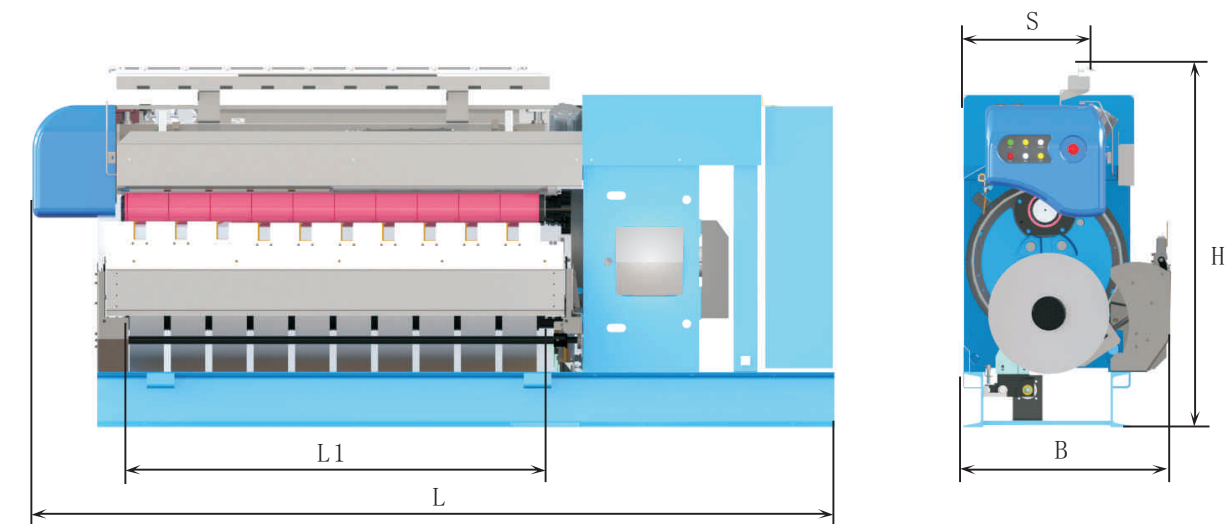

### 主要技术规格 Main Specification:

锭轴长度 Chunk length	卷绕速度 Winding speed	纸管规格 Tube dimension	卷装直径 Package	卷装容积 (dm <sup>3</sup> ) / 动程 (mm) Volume (dm <sup>3</sup> ) / stroke length (mm)					
mm	m/min	Φ	Φ	10	12	14	16	18	20
1500	2500-4500	110*125	435	17.04/125	12.95/95	-	9.95/73	-	7.36/54
1500	2500-5500	125*140	435	16.65/125	12.65/95	-	9.73/73	-	7.19/54
1800	2500-4800	125*140	435	-	16.65/125	-	12.32/92.5	-	9.32/70

### 外形尺寸参数 Dimensions

L1	L	B	H	S
mm	mm	mm	mm	mm
1500	2905	754	1250	463
1800	3355	754	1306	463



## TK系列热辊、分丝辊

### 主要特点

恒天重工华蔡公司TK系列热辊、分丝辊是为民用丝而定制开发的，热辊部分包括导丝盘、加热器、测温传感器、旋转温度变送器、温度控制器等。利用电感应加热，采用热管技术，热辊工作区表面温度均匀。热辊由永磁同步电机驱动精确控制转速，在高速、高温工况下运转平稳可靠，能满足各种FDY民用丝纺丝工艺的要求。

### 适用范围

适用于纺涤纶、锦纶、丙纶以及复合丝等各种民用丝。同时还可根据纺丝品种灵活调整加热、拉伸和定型的工艺路线及参数，纺丝纤度范围40-800dtex

## TK Series Hot Godet Roller(HGR) and Separate Roller(SR)

### Main feature

As a subsidiary of CHTC,Huaying Company TK series HGR and SR are developed for textile yarn,including godet,heater,temperature sensor ,rotary temp transmittor,temperature controller,etc.It adopts heating tube technology and heated by electricity,godet working area surface temperature is uniform.HGR is driven by permanent magnet synchronous motor to control the running speed accurately,it runs stably and reliably on high speed and high temperature condition and can satisfy the process reairurement of various FDY textile yarn.

### Suitable product

It is suitable various kinds of textile yarn.And the heating,stretch and sizing process flow&parameter can be flexible adjusted based on product type,denier range is 40-800Dtex.



陶瓷热辊  
Ceramics HGR



镀铬热辊  
Chrome HGR



分丝辊  
SR

### 主要技术规格 Main Specification:

型号名称 Type	TK1101M 热辊	TK1101N 热辊	Tk1101-450 热辊	TK1101A-450 热辊	TK1101-500 热辊	TK1101A-500 热辊	TK1102E 分丝辊 SR	TK1102-450 分丝辊 SR	TK1102-500 分丝辊 SR
电机型式 Motor Type	4极永磁同步电机 4-Pole Permanent Magnetic Synchronous Motor		4极永磁同步电机 4-Pole Permanent Magnetic Synchronous Motor		4极永磁同步电机 4-Pole Permanent Magnetic Synchronous Motor		2极异步电机 2-Pole Asynchron ous Motor	2极异步电机 2-Pole Asynchron ous Motor	2极异步电机 2-Pole Asynchron ous Motor
辊面尺寸 Dimention	Φ220x350 mm	Φ220x400 mm	Φ220x450 mm	Φ220x450 mm	Φ220x500 mm	Φ220x500 mm	Φ110x350 mm	Φ110x450 mm	Φ220x500 mm
表面处理 Surface treatment	表面 喷陶瓷 Ceramic	表面 镀硬铬 chromium	表面 喷陶瓷 Ceramic	表面 镀硬铬 chromium	表面 喷陶瓷 Ceramic	表面 镀硬铬 chromium	表面 喷陶瓷 Ceramic	表面 喷陶瓷 Ceramic	表面 喷陶瓷 Ceramic
速度范围 Speed range	1000-6000 m/min	1000-4000 m/min	1000-5400 m/min	1000-4000 m/min	1000-5500 m/min	1000-4000 m/min	1000-6000 m/min	1000-5400 m/min	1000-5500 m/min
有效加热 长度 Work length	280mm	330mm	380mm	380mm	430mm	430mm			
表面温度 Surface temperature	50-200℃	50-150℃	50-200℃	50-150℃	50-200℃	50-150℃			
工作区 温差 Speed Range	≤ ± 1.5℃		≤ ± 1.5℃		≤ ± 1.5℃				
测温方式 Sensor Type	Pt100 旋转测温 rotating		Pt100 旋转测温 rotating		Pt100 旋转测温 rotating				
加热功率 Heating ower	11KW	9KW	11KW	11KW	11KW	11KW			
轴承润滑 方式 Bearing Lubrication	油雾润滑 Oil Mist								

## 中控管理系统

中控管理系统可将生产现场的数据汇总联网，形成一个畅通交互的整体，通过中控管理系统即可将整个工厂所有的设备进行实时管理，从而实现数据的实时交换和终端显控，同时可为远程管理提供输出端口和数据库。

## Central control management system

Central control management system can collect the production data networking to be a smooth interaction whole. All the equipments on the plant real-time management can be done by this system, and realize data real-time exchange and indicated & controlled by the terminal. And also can supply output port and data base to remote management.

## 上位机控制系统

上位机系统由公司自主开发，相比传统的WINCC、组态王等软件有响应快、扩展性好等优点。上位机可实现纺丝+卷绕联合控制，并且数据刷新速度达到毫秒级。经过多年精心优化，系统在功能及用户体验上已达到国际同等水平，主要功能参数读写、工艺配方、工艺组态、状态监控、趋势监测、故障记录、产量报表等。

## Interface of control system (DCS system)

DCS system was self-developed by Huaying company. It has the advantages of rapid reaction, good expansibility, etc. compared with traditional WINCC and King View, etc. DCS system can realize spinning + take up combined control and the data refresh speed can reach millisecond class. After many years optimization, this system has reached international equal level on function and user experience. Main functions are parameter reading and writing, technical formula, process configuration, condition monitoring, trend monitoring, faulty record, production report, etc.

